

# Movopart M55, M75 and M100

## Installation and service manual

<b>Section 1 Introduction .....</b>	<b>2</b>
<b>Section 2 Type designation system .....</b>	<b>3</b>
<b>Section 3 Installation .....</b>	<b>4</b>
3.1 Mounting instructions .....	4
3.2 Connection to saddles .....	5
3.3 Installation of adapter plates, limit switch brackets and sensor brackets .....	5
3.3 Connection to the motor flange .....	6
<b>Section 4 Service and maintenance .....</b>	<b>7</b>
4.1 Introduction .....	7
4.2 General maintenance instructions .....	7
4.3 Replacement of cover band .....	7
4.4 Lubrication of screw .....	8
4.5 Lubrication of ball slides .....	9
4.6 Control and adjustment of belt position .....	10
4.7 Control and adjustment of the belt tension .....	11
4.8 Control and adjustment of saddle play in MG06(07/10)B***A .....	12
4.9 Control and adjustment of saddle play in MG06(07/10)B***C or MG06(07/10)N .....	13
4.10 Control and adjustment of saddle play in MG06(07/10)K or MG06(07/10)C .....	14
4.11 Replacement of belt in MF06(07/10)B .....	15
4.12 Replacement of belt in MG06(07/10)B***A .....	16
4.13 Replacement of belt in MG06(07/10)B***C .....	17
<b>Section 5 Technical data .....</b>	<b>18 - 19</b>

## Section 1 Introduction

Movopart M100, M75 and M55 are a range of linear rodless actuators in different sizes which all shares the same basic design. This means that most of the instructions in this manual is valid for M100, M75 and M55. It is clearly stated in such cases where the differences are important.

All sizes can be divided up into three types – those that use a ball screw transmission, those that use a belt and lastly those that are undriven (without a transmission). These three types can in turn be divided up into those using ball guides and those using prism guides (slide bearings) as a bearing for the saddle, which constitutes the moving part of the Movopart. These basic types are available in a number of different configurations which can be studied in the type key on next page.

In order to be able to use this manual properly, it is important to understand which size and type of Movopart you have. Feel free to contact Tollo Linear AB if there are any doubts as to the type or if you have any other questions. When you do so, please state the manufacturing number and the type designation of the Movopart, see figure 1.

### Important!

- Read through this manual before beginning the installation or servicing and follow all applicable directions in order to ensure a safe and proper job.
- In order to ensure a long life and reliable functionality, the Movopart must be serviced according to the directions found in this manual. Spare parts should be by the same manufacturer and of the same type as the original or be among those approved in writing by Tollo Linear AB. Never use parts which work improperly or seems damaged.
- The system or machine part of which the Movopart is a component must not be used before it is in compliance with the EU's Machinery Directive in those instances where it is to be used within the EEC area.
- If possible, never work with power, compressed air or hydraulics turned on. If the work must be performed with some of these turned on, another person must be positioned so that the power, compressed air or hydraulics can be turned off in the event of any mishap.

## Section 2 Type designation system

M	F	07	K	20	7	A	00	X	...
Metric.....M									
Ball guides.....F									
Prism guides.....G									
Profile size.....M100.....10									
.....M75.....07									
.....M55.....06									
Belt operation.....B									
Ball screw + ball nut.....K									
Ball screw + composite nut.....C									
Undriven.....N									
Screw pitch.....5 mm.....05									
.....5.08 mm.....U5									
.....10 mm.....10									
.....12.7 mm.....12									
.....20 mm.....20									
.....25 mm.....25									
.....32 mm.....32									
Linear movement at belt operation...105 mm.....105									
...130 mm.....130									
...176 mm.....176									
Tolerance class for ball screws.....T5.....5									
.....T7.....7									
.....T9.....9									
Single saddle.....A									
Double saddle.....C									
Standard at single saddles.....00									
Lc for M100 (c/c distance between two saddles in cm).....35 – 99									
Lc for M75 (c/c distance between two saddles in cm).....25 – 99									
Lc for M55 (c/c distance between two saddles in cm).....20 – 99									
Without screw support.....X									
Single screw support.....S									
Double screw support.....D									
or at									
Special Movopart units.....M									
Length in cm (se measure L in figure 1).....050 – 999									
or									
Sequential number for special Movopart units.....000 – 999									

Table 1: Type designations

## Section 3 Installation

### 3.1 Mounting instructions

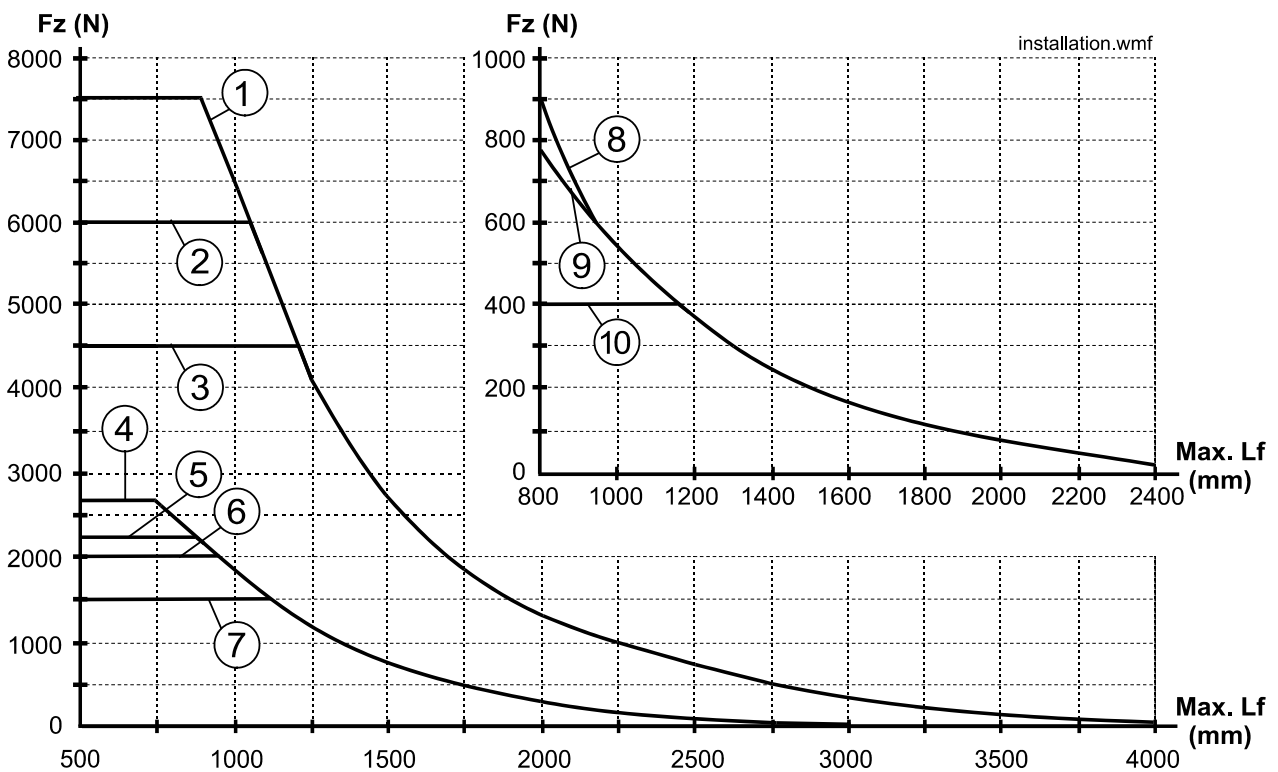
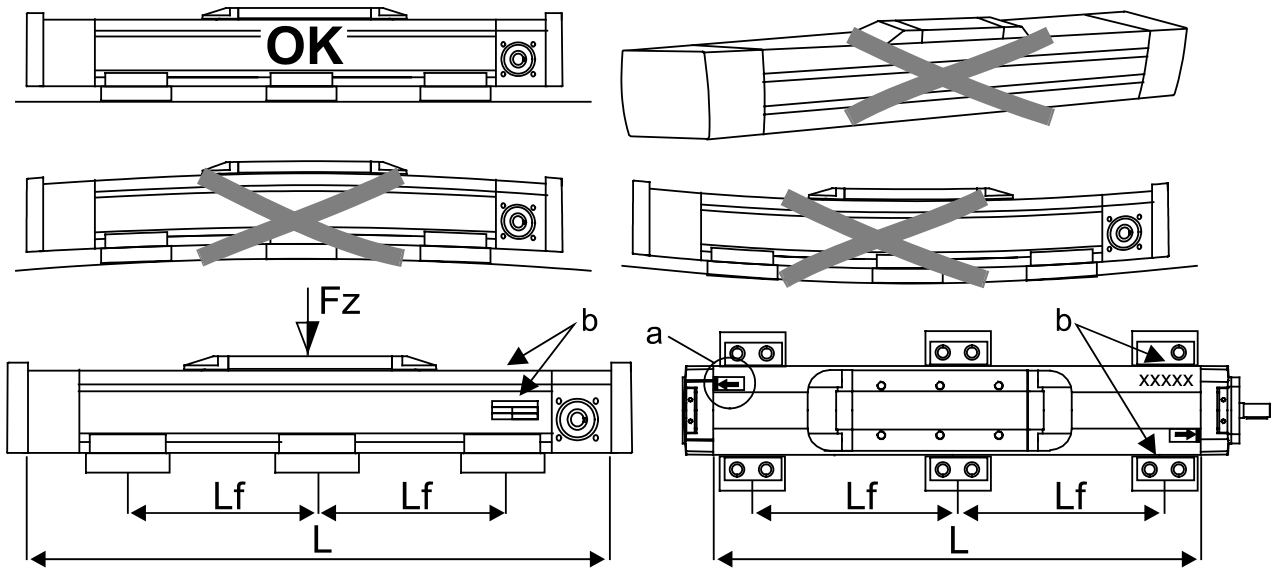

Figure 1: Mounting instructions

- |                               |                 |                  |
|-------------------------------|-----------------|------------------|
| 1. MF10C, MF10K               | 5. MG07B, MG07N | 9. MF06B         |
| 2. MF10B, MF10N, MG10B, MG10N | 6. MF07C, MF07K | 10. MG06K, MG06B |
| 3. MG10C, MG10K               | 7. MG07C, MG07K |                  |
| 4. MF07B, MF07N               | 8. MF06K        |                  |

Place the unit on the mounting surface. Place shims at the mounting points so that the unit keeps its shape and is not bent or twisted in any direction. The distance between each mounting point must not exceed the max. permissible mounting distance (Max. Lf) for the max. load being moved (Fz) by the unit. After the mounting of a belt driven unit, see point 4.6. Never run the saddle past the arrows (a) on the profile. At ordering of spare parts, please state the manufacturing number and the type designation of the Movopart (b).

### 3.2 Connection to saddles

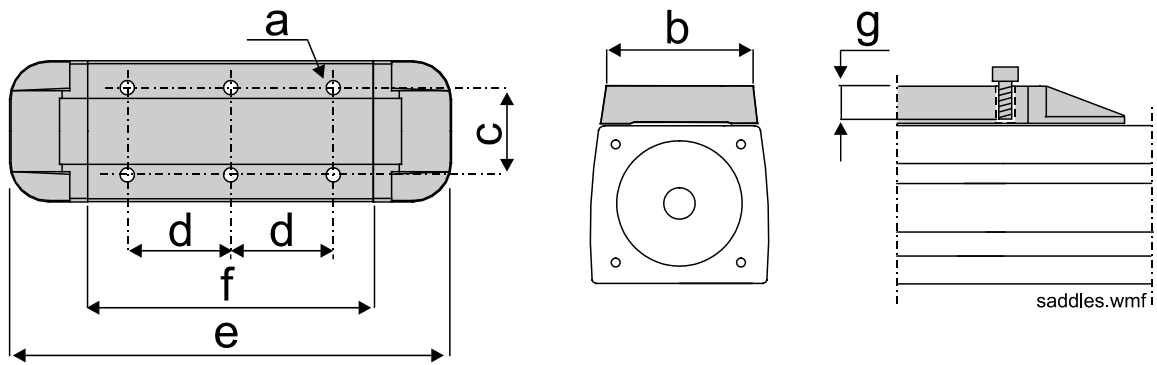

Figure 4: Saddle dimensions

Movopart	a	b	c	d	e	f	g
M100	M10 (6x)	93	60	71	306	198	15
M75	M8 (6x)	76	60	53	218	144	12
M55	M5 (6x)	49	41	38	184(234*)	118 (168*)	9

\* = only for MF06B

Table 2: Saddle dimensions

### 3.3 Installation of adapter plates, limit switch brackets and sensor brackets

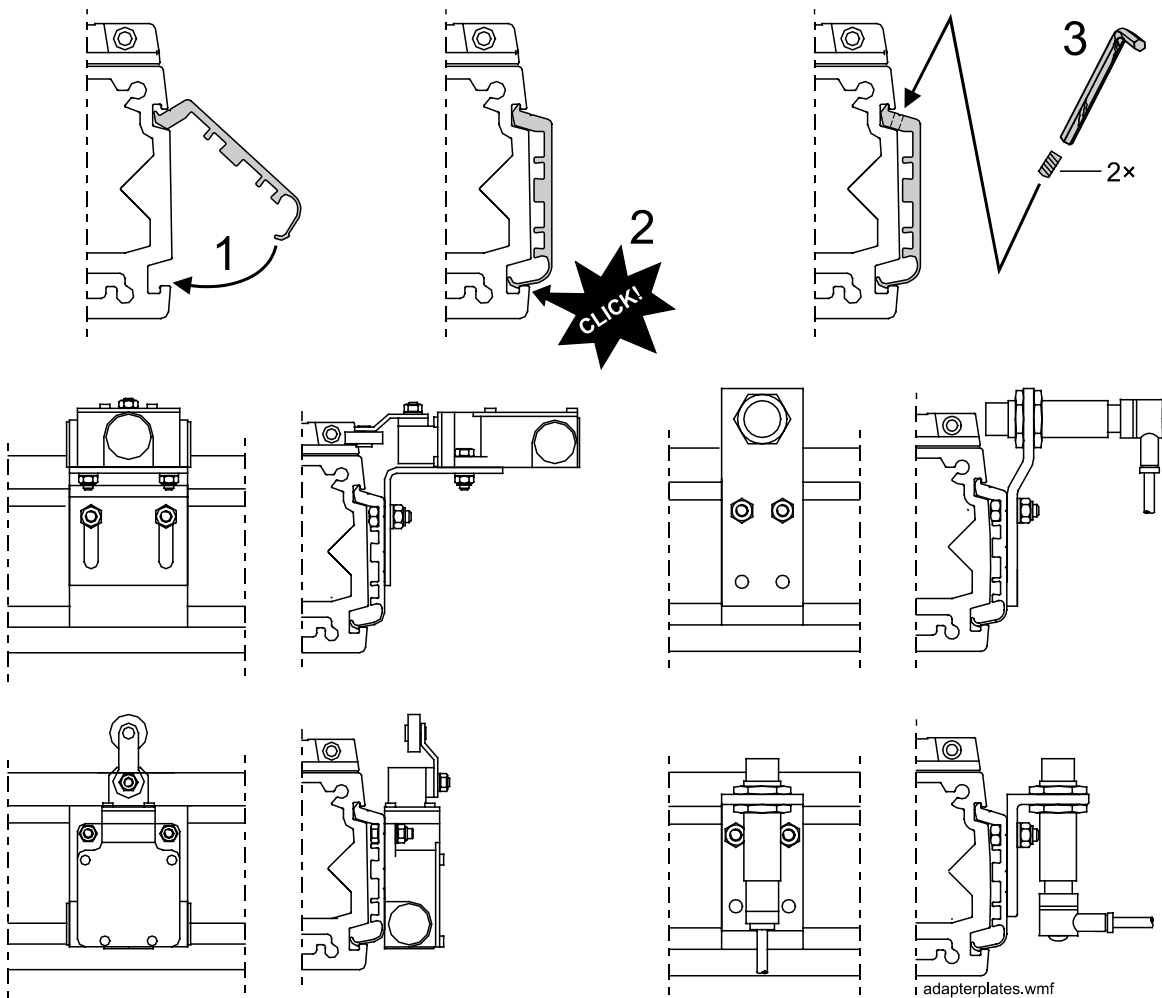

Figure 3: Installation of adapter plates, limit switch brackets and sensor brackets

### 3.4 Connection to the motor flange

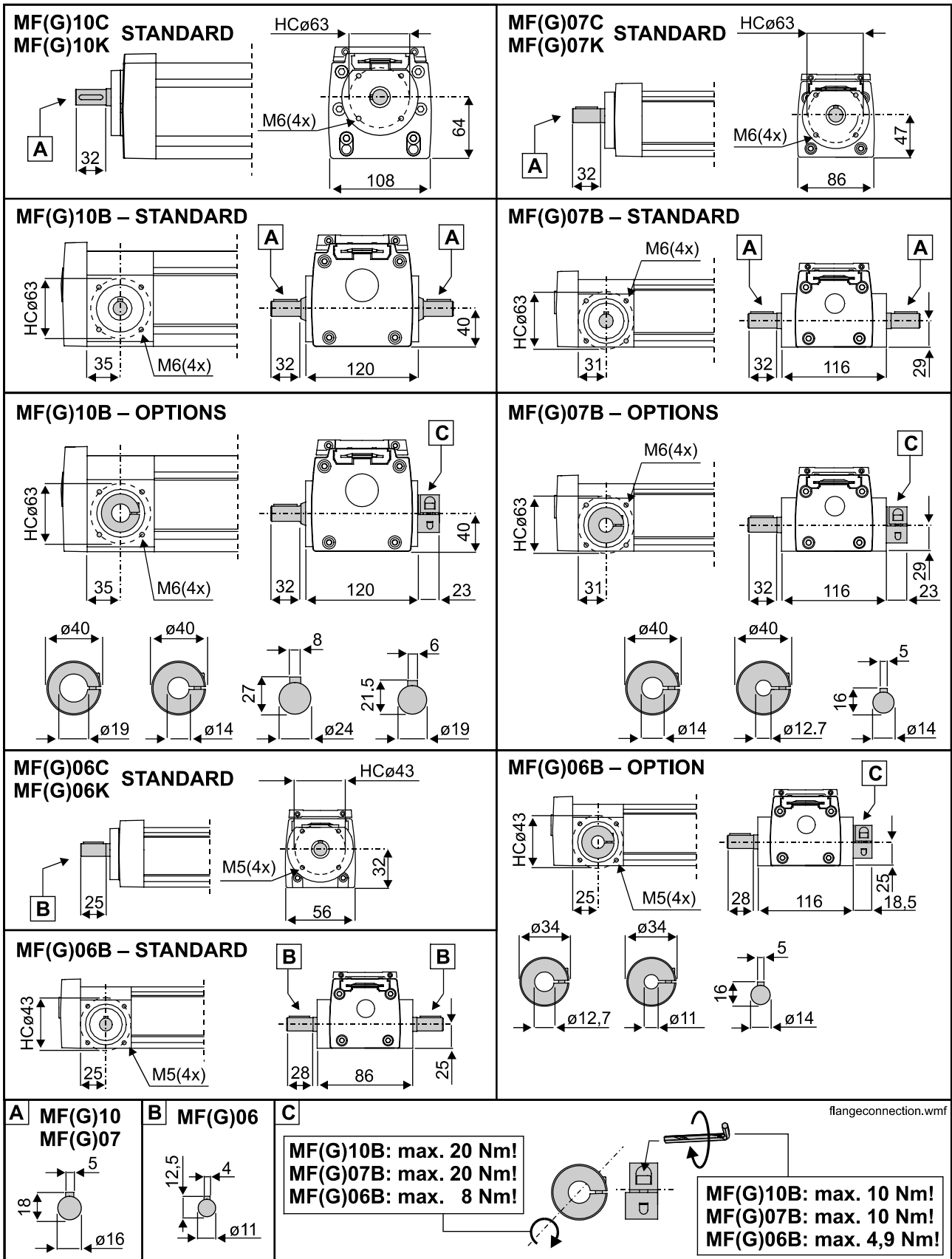

Figure 4: Connections to the motor flange

## Section 4 Service and maintenance

### 4.1 Introduction

The customer can perform the service and maintenance described in this manual. Some steps however require special tools. These steps are marked with the tool symbol. The tools can be ordered from Tollo Linear AB and their ordering data is found in respectively instruction. Other service ought to be performed by service personnel from Tollo Linear AB, either on-site or at a Tollo Linear AB Service Centre.



Tool symbol

### 4.2 General maintenance instructions

- Movopart M100, M75 and M55 are not self-braking. This means that the load can move if the driving force is disconnected, or if the motor, gears or brakes are detached during service. This is even more important for vertical applications. Ensure therefore that the load is secured before service is begun.
- Follow the recommended service intervals. Replace defective parts immediately. Only use parts of the same make and type as original. Ordering data can be found in the spare part lists supplied with the unit. Also state the manufacturing number of the unit (embossed in the drive end).
- Check the unit at least once a month, particularly the cover band, the saddle ends and connections to the foundation and the saddles. Also be attentive towards a changed level of noise. Replace, repair or adjust.
- Keep the Movopart clean. Wipe it off as required, particularly the cover band. If cleaning fluid is required, use small amounts and see to it that none gets into the Movopart, do not use strong cleaning agents. Dry it fully.
- **Never** mix different types of oils / lubricants!

### 4.3 Replacement of cover band

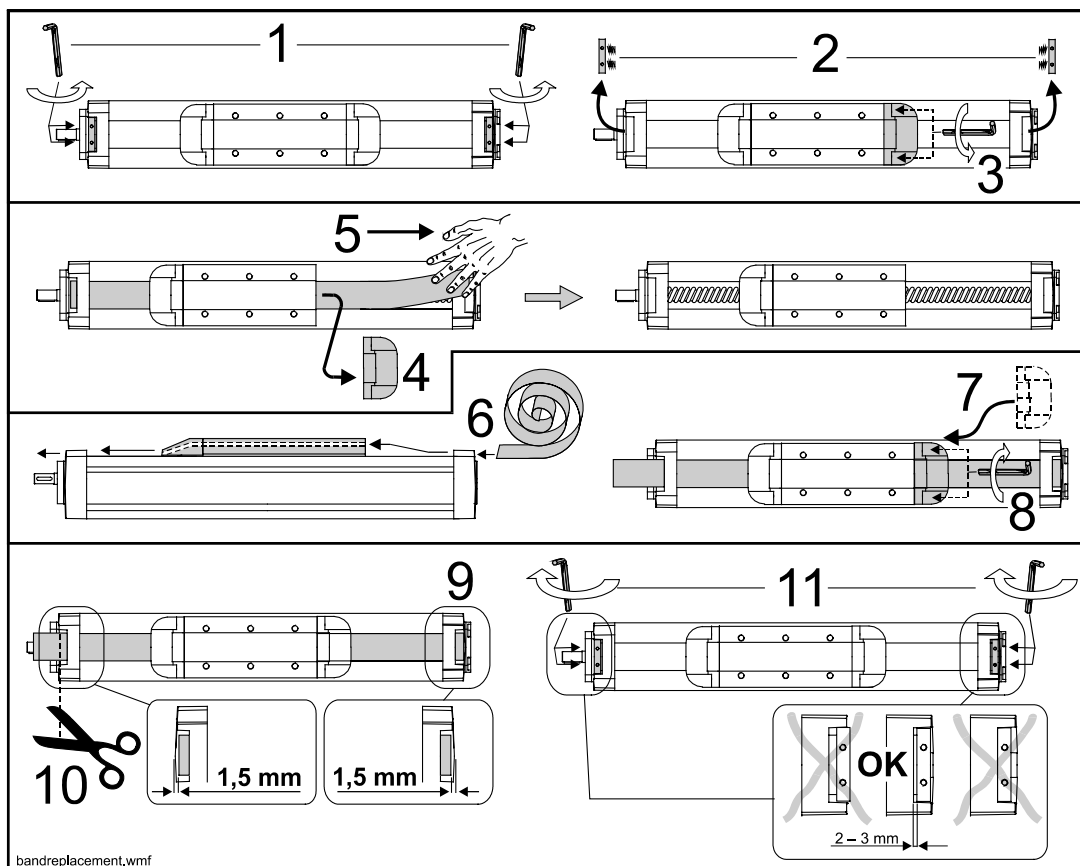

Figure 5: Replacement of cover band

#### 4.4 Lubrication of screw

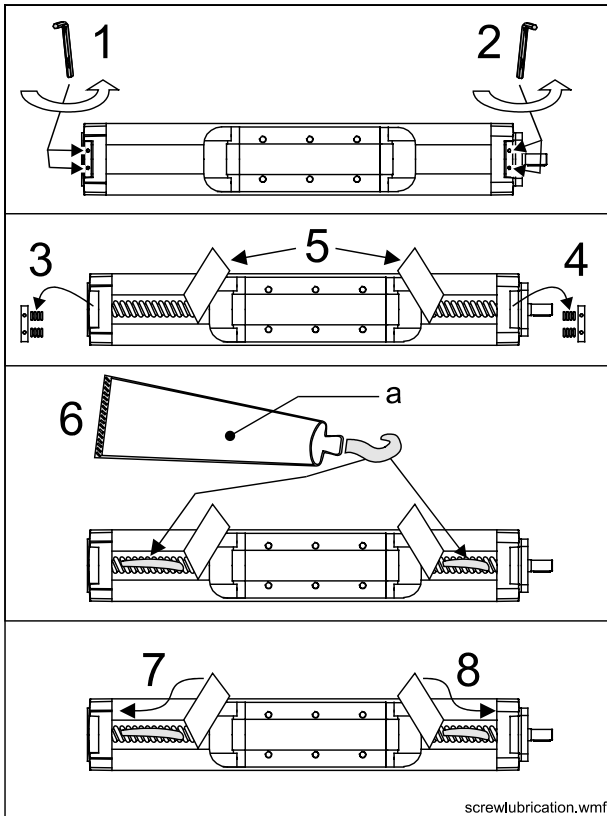
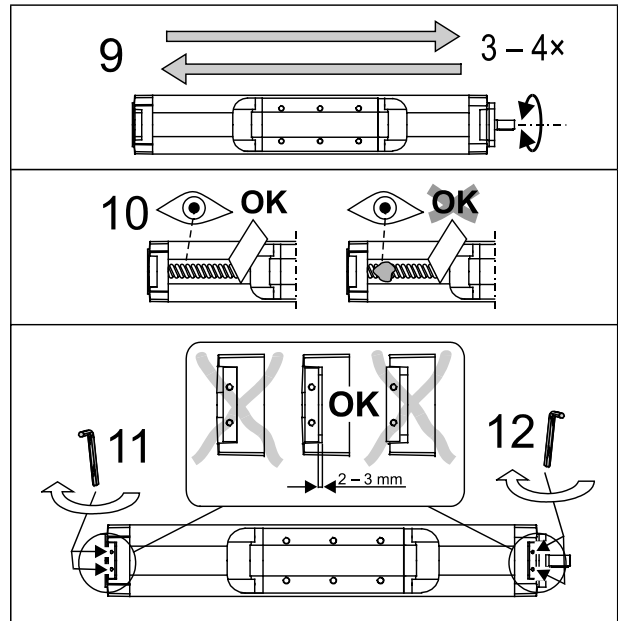

Figure 6: Lubrication of screw

Apply the grease where the saddle can reach it. Run the unit back and forth 3 – 4 times. At last, remove any excessive grease.



Type of Movopart	Lubrication intervals	Type of grease (a)
MF(G)10(07/06)K	every 6 months	SKF LGMT2
MF(G)10C	every 6 months	Klüber Starburags NBU30
MF(G)06C	first lubrication after 10 000 m, then every 6 months	Klüber Polylub GA352P

Table 3: Lubrication intervals and type of grease



#### 4.5 Lubrication of ball slides

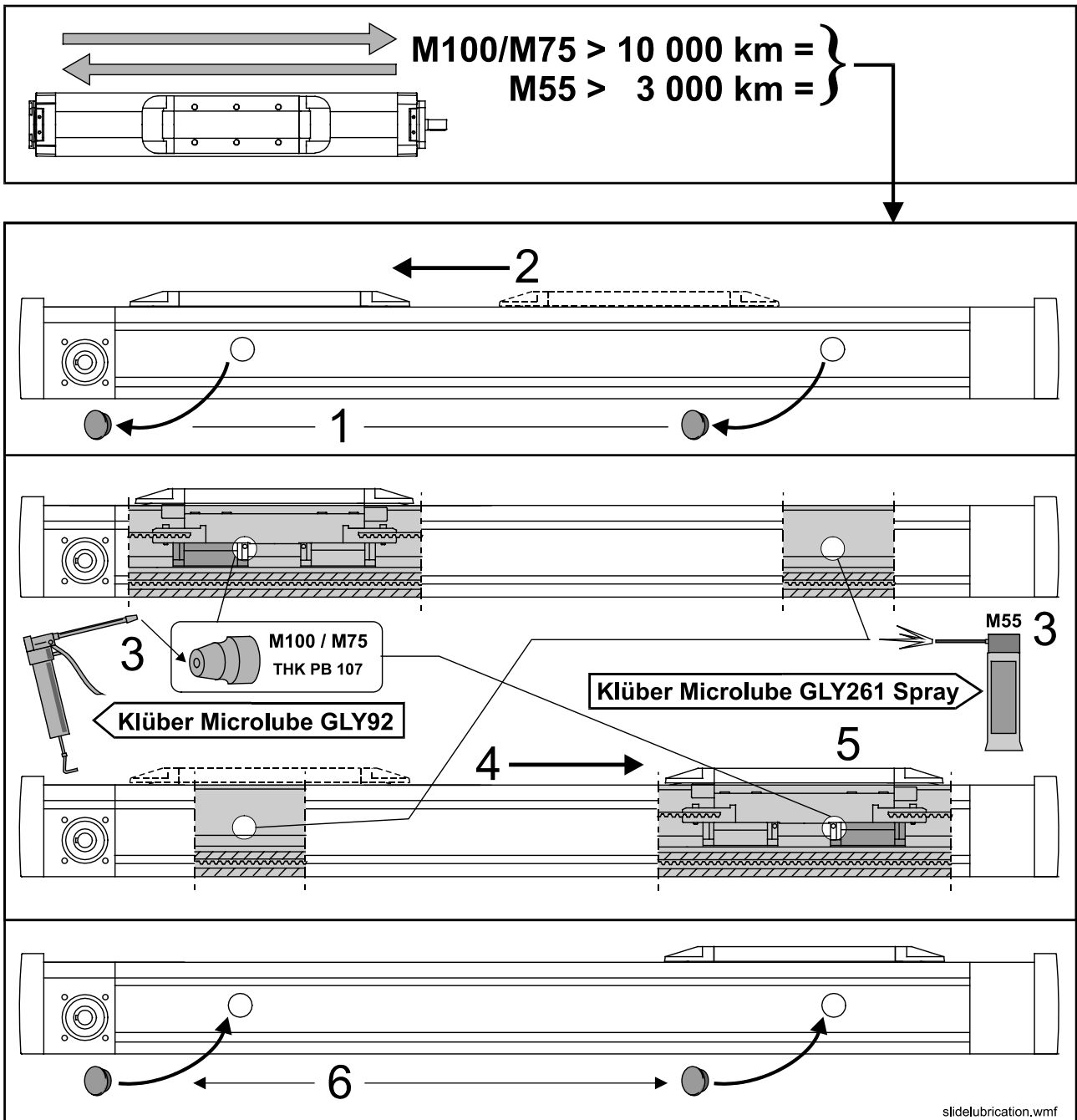

Figure 7: Lubrication of ball slides

#### 4.6 Control and adjustment of belt position

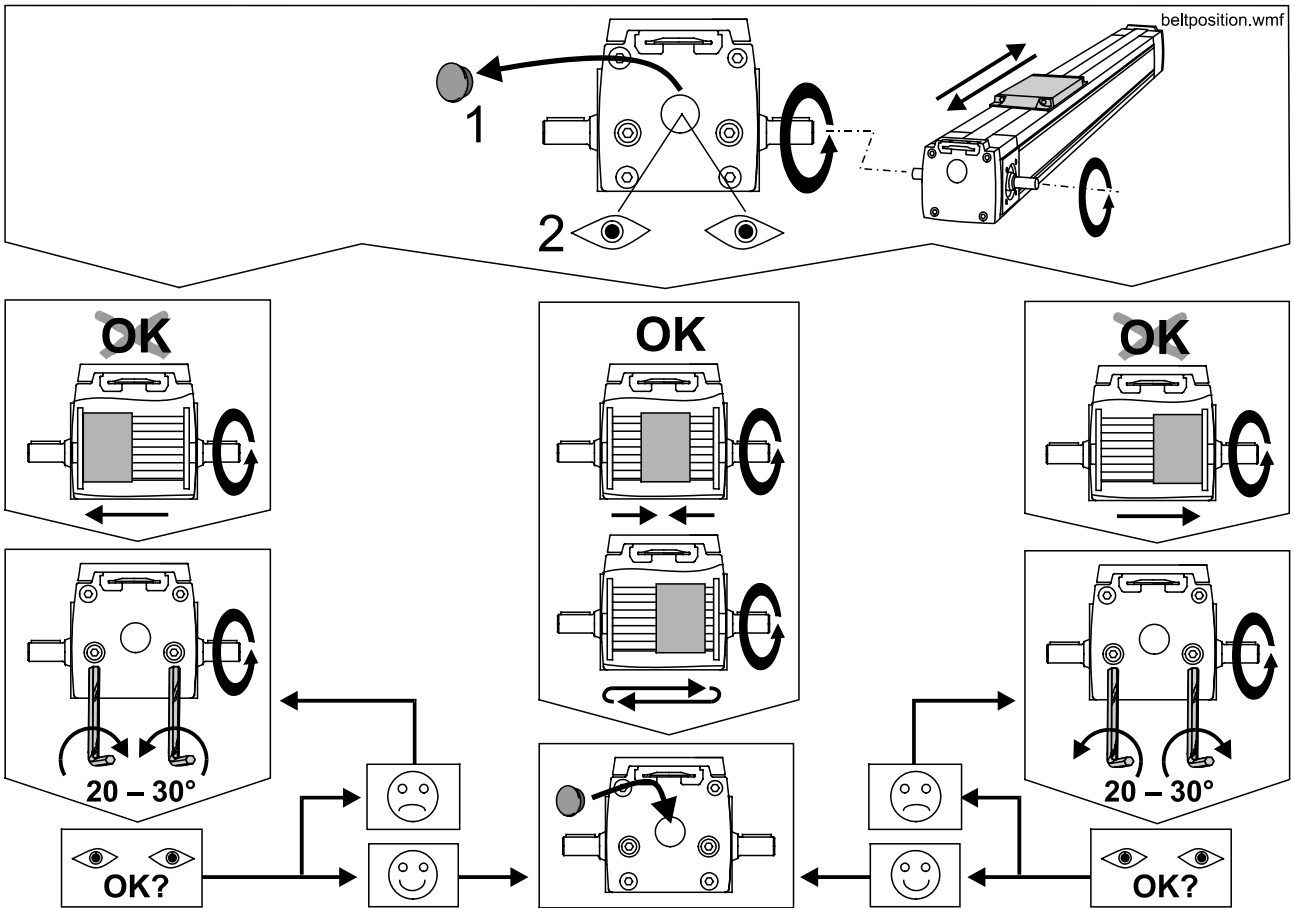

Figure 8: Control and adjustment of belt position

Check the belt position after installation of a belt driven unit or a belt replacement. The belt shall during operation lie in the centre or wander from side to side of the tension pulley, otherwise adjust. Check the belt tension before any adjustment, see point 4.7. Turn the adjustment screws max. 20 – 30° and check, repeat until position is correct.

#### 4.7 Control and adjustment of belt tension

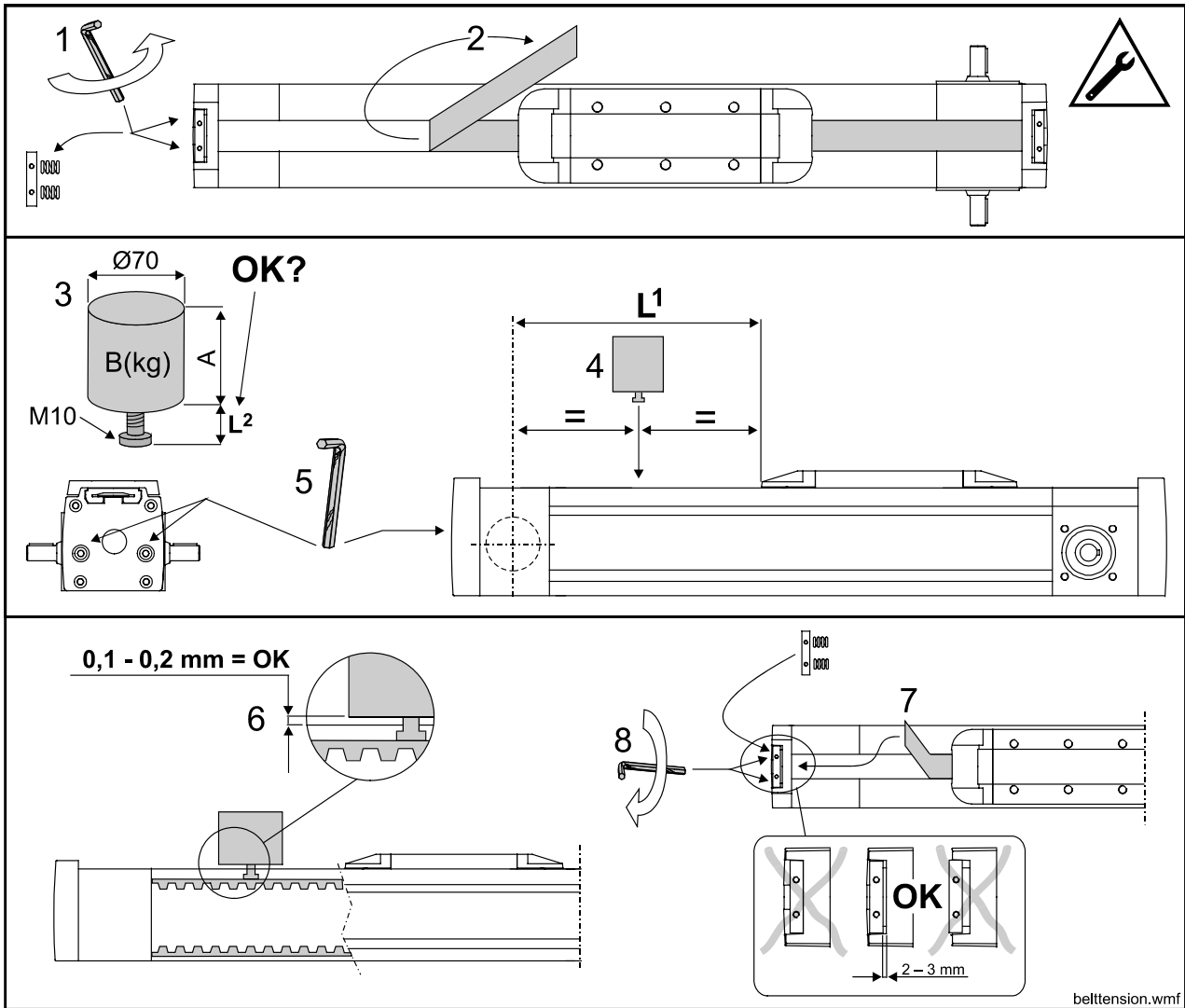

Figure 9: Adjustment of belt tension

Check the belt tension after belt replacement. The belt tensioning weight is purchased from Tollo Linear AB (ordering data, see table below) or made on-site out of a round piece of steel as shown in the sketch above. Check the belt position when the belt tension is set, see point 4.6.

1. Remove the cover band holder.
2. Fold back the cover band.
3. Set the  $L^2$  dimension with respect to dimension  $L^1$ .
4. Place the weight so that the bolt rests on the belt.
5. Hold the saddle in place and turn the belt tensioning screws in order to raise or lower the weight. Turn identical amounts on both screws.
6. When the weight lifts above the profile (0.1 – 0.2 mm) the belt tension is correct.
7. Put the cover band back in place.
8. Fasten the cover band holder.

Movopart type	$L^1$ (mm)	$L^2$ (mm)	A (mm)	B (kg)	Weight designation	Part number
M100	500	32.7	106.0	3.2	RSV100	D350 980
M100	1000	35.9	106.0	3.2	RSV100	D350 980
M75	500	26.3	106.0	3.2	RSV75	D350 980
M75	1000	30.8	106.0	3.2	RSV75	D350 980
M55	500	19.3	56.5	1.7	RSV55	D350 981

Table 4: Belt tensioning table

#### 4.8 Control and adjustment of saddle play in MG06(07/10)B\*\*\*A

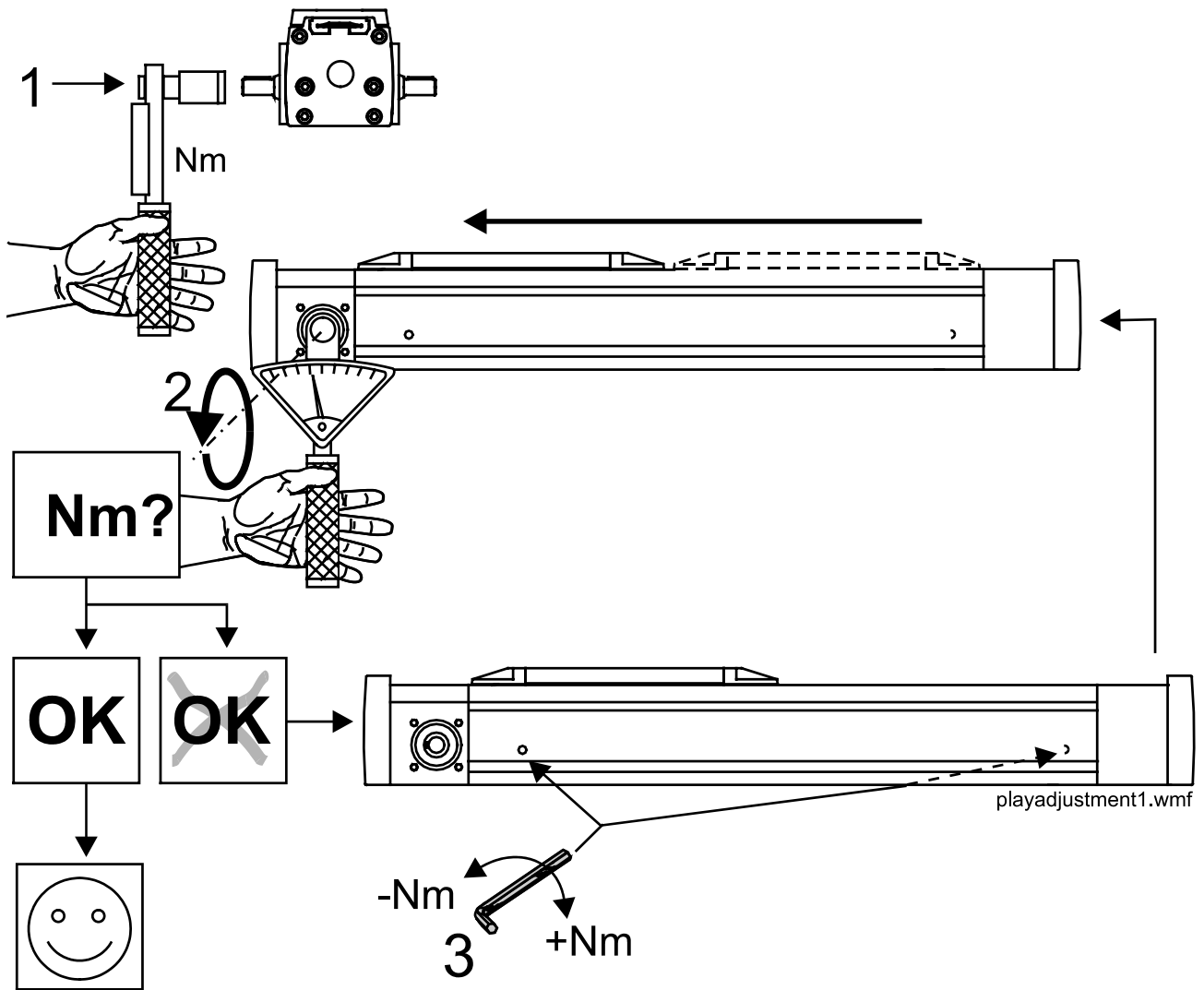

Figure 10: Adjustment of prism bushings in belt driven units with single saddle

Possible saddle play due to wear can be adjusted for. If the play does not matter for the operation no adjustment is needed. Detach any possible gear box, motor or saddle load before adjustment. Check the belt tension before adjustment, see point 4.7.

1. Connect a torque wrench to the drive shaft. Select a wrench which do not damage the shaft when the shaft is turned.
2. Turn the torque wrench so that the saddle moves along the entire profile. Compare the indication with the table below. If the value equals the table value the play is correct. If it is less the play is too large and if it is higher the play is too small.
3. Adjust if needed trough the adjustment holes (one on each side). Adjust all four prism bushings on the saddle equally much. Pull the saddle until the respective adjustment screw becomes accessible. Tighten or loosen each screw  $\pm 40$  degrees or less. Check again. Repeat until the play is correct.

Movopart type	Approximate value (Nm)
M100	3.8
M75	2.2
M55	2.1

Table 5: Adjustment table for prism bushings in belt driven units with single-saddle

#### 4.9 Control and adjustment of saddle play in MG06(07/10)B...C or MG06(07/10)N

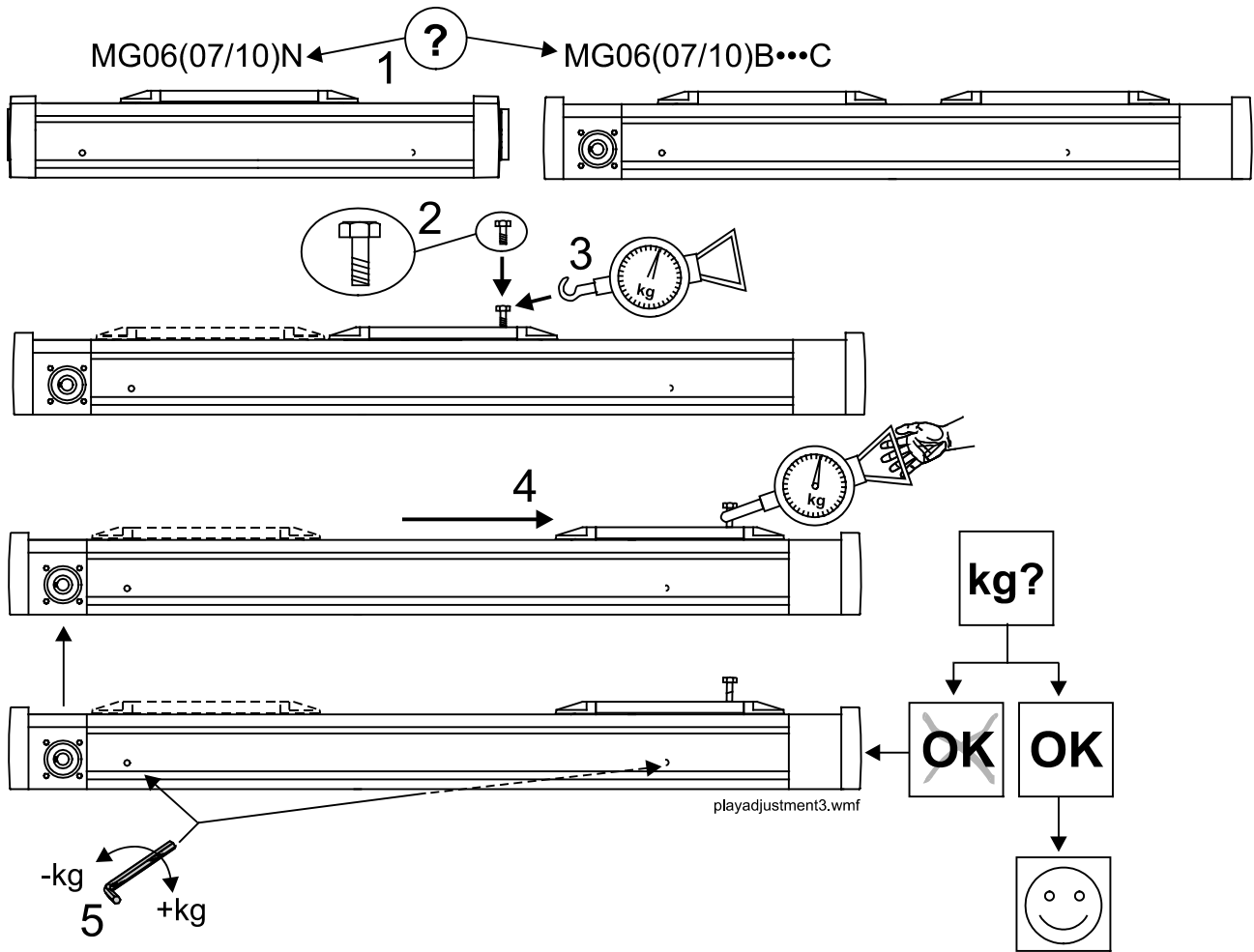

Figure 11: Prism bushing adjustment for undriven or belt driven units with double saddles

Possible saddle play due to wear can be adjusted for. If the play does not matter for the operation no adjustment is needed. Detach any possible gear box, motor or saddle load before adjustment. At belt operation, also check the belt tension before adjustment, see point 4.7.

1. For undriven units all saddles are checked as per the scale method described below. For belt driven units with double saddles the driven saddle is checked as an A saddle with a torque wrench as described in point 4.8 while the undriven saddle is checked with the scale method described below.
2. Fasten a bolt in the saddle.
3. Connect a scale to the bolt.
4. Pull the saddle along the entire profile. Compare the indication with the table below. If the value equals the table value the play is correct. If it is less the play is too large and if it is higher the play is too small.
5. Adjust if needed through the adjustment holes (one on each side). Adjust all four prism bushings on the saddle equally much. Pull the saddle until the respective adjustment screw becomes accessible. Tighten or loosen each screw  $\pm 40$  degrees or less. Check again. Repeat until the play is correct.

Movopart type	Bolt size	Approximate value (kg)
M100	M10	4.0 – 4.5
M75	M8	3.5 – 4.0
M55	M5	3.0 – 3.5

Table 6: Adjustment table for prism bushing in undriven saddles

#### 4.10 Control and adjustment of saddle play in MG06(07/10)K or MG06(07/10)C

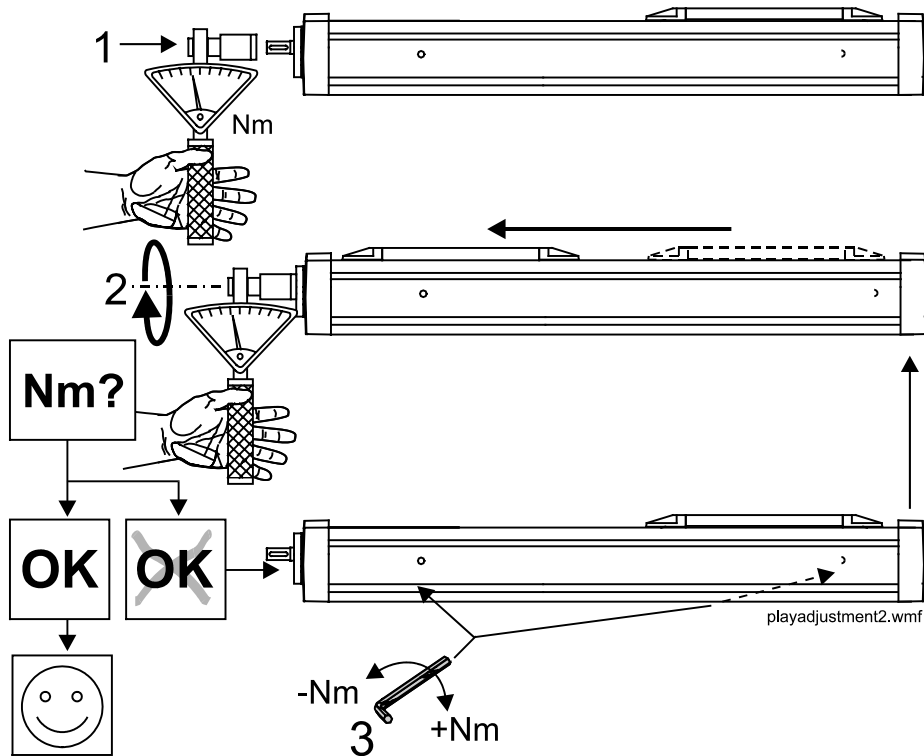

Figure 12: Adjustment of prism bushings in ball screw driven units

Possible saddle play due to wear can be adjusted for. If the play does not matter for the operation no adjustment is needed. Detach any possible gear box, motor or saddle load before adjustment.

##### Single saddle (A-saddle):

1. Connect a torque wrench to the drive shaft. Select a wrench, which do not damage the shaft when turned.
2. Turn the torque wrench so that the saddle moves along the entire profile. Compare the indication with the table below. Remember to add torque for any screw supports. If the value equals the table value the play is correct. If it is less the play is too large and if it is higher the play is too small.
3. Adjust if needed through the adjustment holes (one on each side). Adjust all four prism bushings on the saddle equally much. Pull the saddle until the respective adjustment screw becomes accessible. Tighten or loosen each screw  $\pm 40$  degrees or less. Check again. Repeat until the play is correct.

##### Double saddles (C-saddle):

For double saddles, one saddle is driven while the other is undriven. The driven saddle is checked as per the instruction above for A-saddle / B-saddle while the undriven is checked as per the scale method (point 4.9).

Lead (mm)	M100 torque (Nm)			M75 torque (Nm)			M55 torque (Nm)		
	A-saddle	1 x ST	2 x ST	A-saddle	1 x ST	2 x ST	A-saddle	1 x ST	2 x ST
5	0.15	+ 0.05	+ 0.10	0.10	+ 0.05	+ 0.05	0.10	+ 0.03	+ 0.03
5.08	–	–	–	–	–	–	0.10	+ 0.03	+ 0.03
10	0.25	+ 0.15	+ 0.15	–	–	–	0.15	+ 0.06	+ 0.12
12.7	–	–	–	0.24	+ 0.15	+ 0.15	–	–	–
20	–	–	–	0.37	+ 0.20	+ 0.20	0.30	+ 0.15	+ 0.15
25	0.55	+ 0.30	+ 0.30	–	–	–	–	–	–
32	–	–	–	–	–	–	0.8	+ 0.20	+ 0.20

ST = screw support

Table 7: Adjustment table for prism bushings in ball screw driven units

#### 4.11 Replacement of belt in MF06(07/10)B

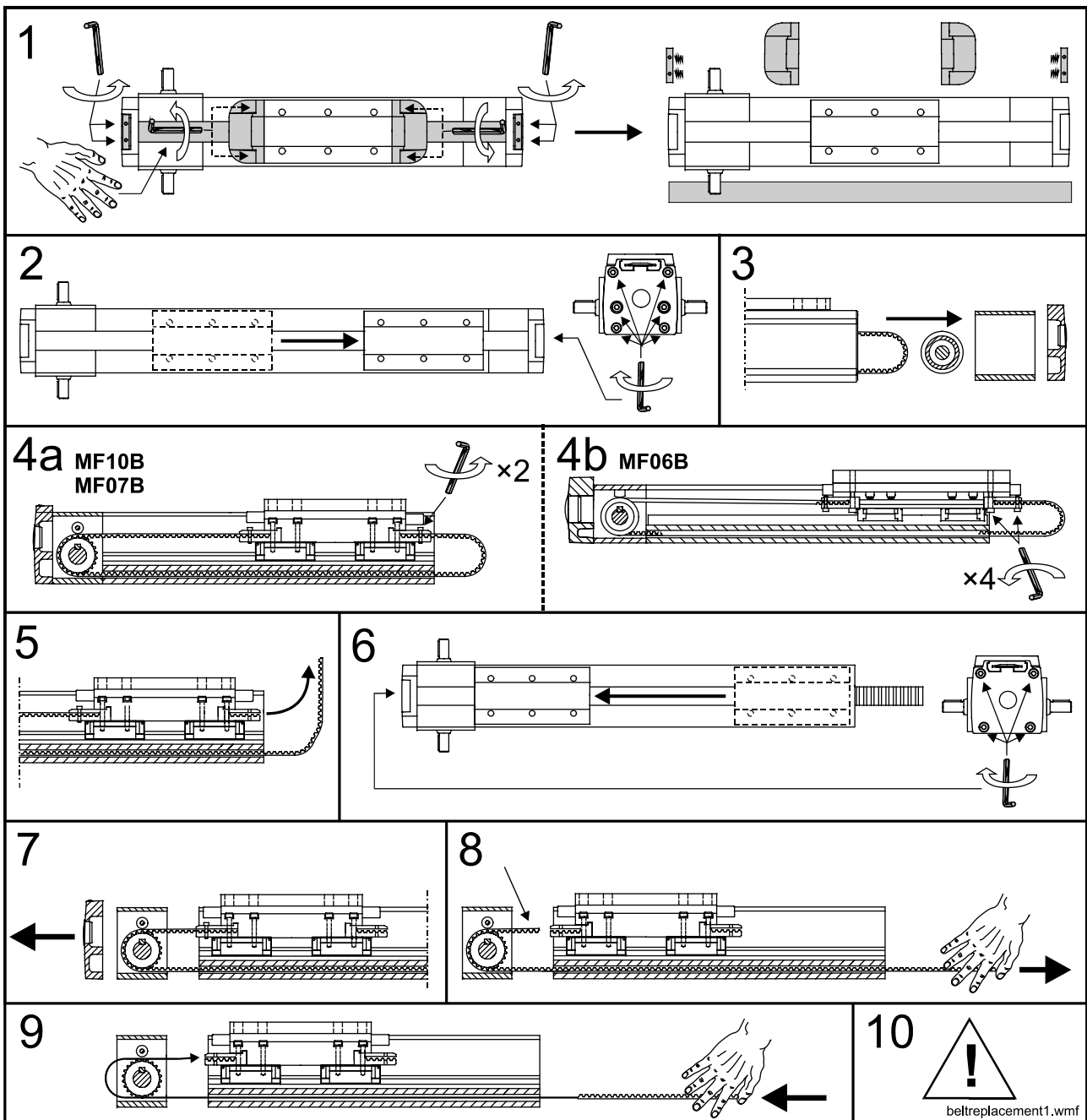

Figure 13: Replacement of belt in ball guided units

Replacement is done in the same way with double saddles (C-saddle) and single saddles (A-saddle).

1. Remove the cover band holder, the cover band and all saddle ends.
2. Move the saddle(s) to the tension-station. Loosen all bolts in the tension station.
3. Remove the end cover, the tension-station and the tension pulley.
- 4a. For MF10B and MF07B: remove the two belt holder screws.
- 4b. For MF06B: remove the two outer belt holder screws and loosen the two inner screws.
5. Remove the belt from the belt holder.
6. Move the saddle to the drive-station. Loosen all bolts in the drive-station.
7. Remove the end cover and pull out the drive-station.
8. Remove the belt holder screws, see point 4a or 4b. Pull out the belt.
9. Insert the new belt. Reassemble the unit in reverse order.
10. When mounting the cover band, see point 4.3. After reassembly, adjust the belt tension (point 4.7) and check the belt position (point 4.6).

#### 4.12 Replacement of belt in MG06(07/10)B...A

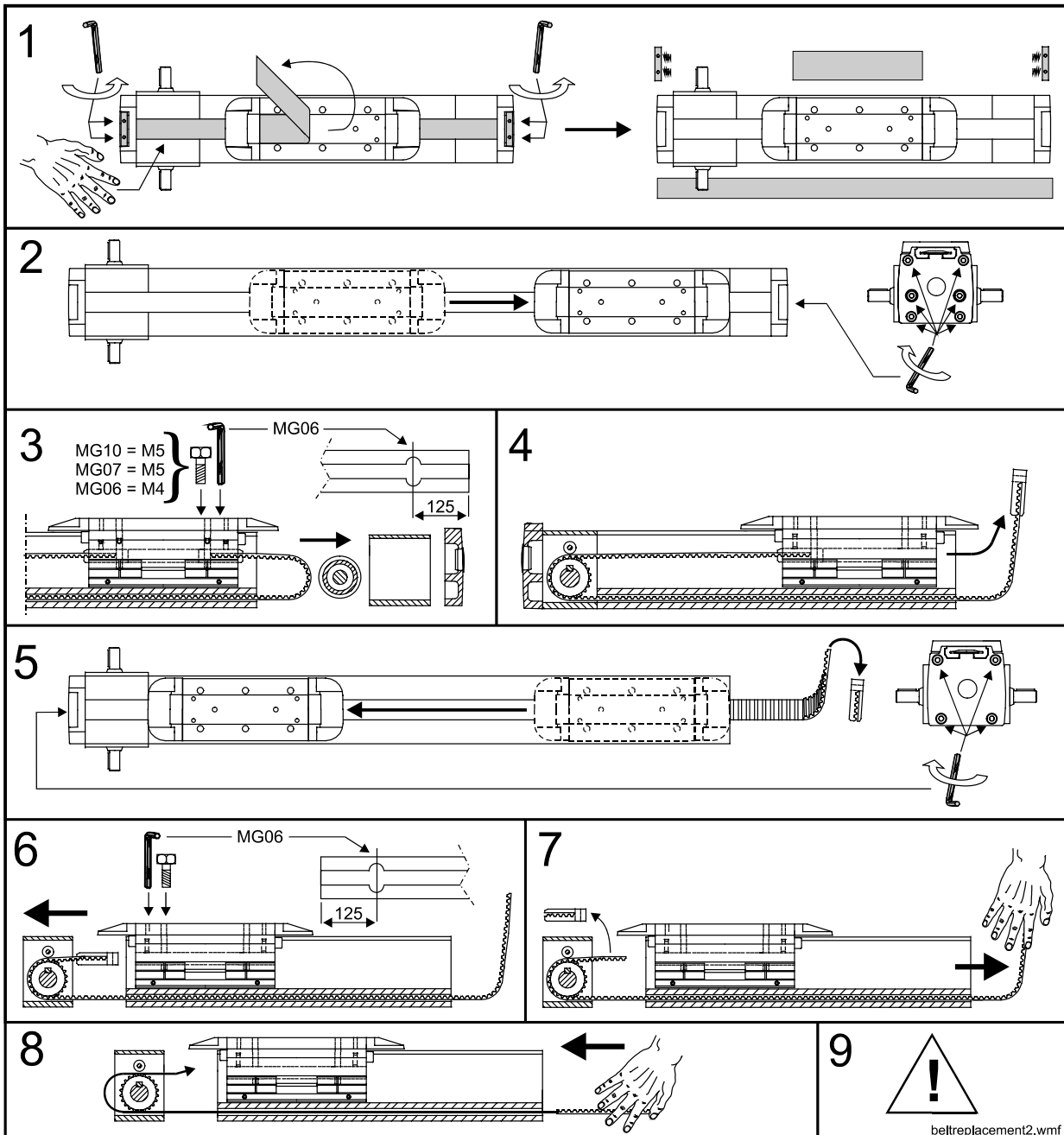

Figure 14: Replacement of belt in prism guided units with single saddle

1. Remove the cover band holders, the cover band and the saddle ends.
2. Move the saddle to the tension-station. Loosen all bolts in the tension-station.
3. Remove the end cover, the tension-station and the tension pulley. Loosen the two socket head cap screws (at M55: use the slots) and insert a screw in the inner hole. Pull up the belt holder pin with the aid of the screw.
4. Remove the belt from the saddle.
5. Remove the belt holder. Move the saddle to the drive-station. Loosen all bolts in the drive-station.
6. Loosen the two socket head cap screws (at M55: use the slots) and insert a screw in the inner hole. Pull up the belt holder pin with the aid of the screw. Remove the end cover and pull out the drive-station.
7. Remove the belt holder and pull out the belt.
8. Insert the new belt. Reassemble the unit in reverse order. Fasten the belt holders with the pins. Do not tighten the socket head cap screws.
9. See point 4.3 when mounting the cover band. After the reassembly, adjust the belt tension (point 4.7) and check the belt position (point 4.6). At last, tighten all the belt holder socket head cap screws.



#### 4.13 Replacement of belt in MG06(07/10)B...C

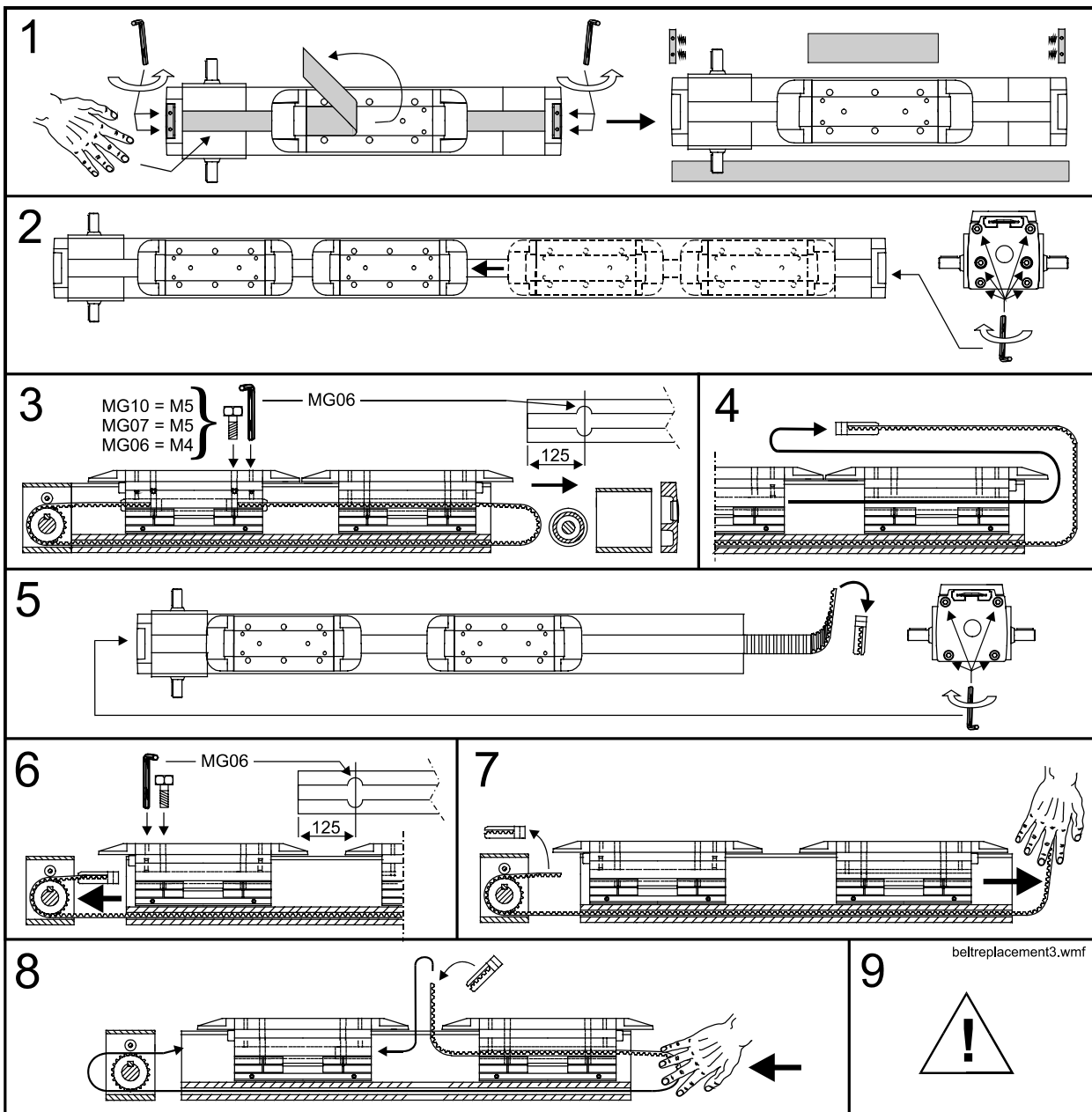

Figure 15: Replacement of belt in prism guided units with double saddles

1. Remove the cover band holders, the cover band and all the saddle ends.
2. Move the saddles to the drive-station. Loosen all bolts in the tension-station.
3. Remove the end cover, the tension-station and the tension pulley. Loosen the socket head cap screws (at M55: use the slots) and insert a screw in the inner hole in the driven saddle. Pull up the belt holder pin with the aid of the screw.
4. Remove the belt from the driven saddle trough the undriven.
5. Remove the belt holder. Loosen all bolts in the drive-station.
6. Loosen the two socket head cap screws (at M55: use the slots) and insert a screw in the inner hole. Pull up the belt holder pin with the aid of the screw. Remove the end cover and pull out the drive-station.
7. Remove the belt holder and pull out the belt from the profile.
8. Put one of the belt ends trough the undriven saddle. Pick up the belt end between the saddles and fit the belt holder. Put the belt down in to the profile again and fit the beltholder to the saddle. Put the other belt end trough the profile to the drive-station. Then reassemble the unit in reverse order. Fasten the belt holders with the pins but do not tighten the belt holder socket head cap screws.
9. See point 4.3 when mounting the cover band. After the reassembly, adjust the belt tension (point 4.7) and check the belt position (point 4.6). At last, tighten all the belt holder socket head cap screws.

## Section 5 Technical data

Movopart MF(G)10C(K)		MF10C, MF10K	MG10C, MG10K
Max. speed	(m/s)	0.25 <sup>A,C</sup> 0.5 <sup>B</sup> 0.625 <sup>E</sup> 1.25 <sup>D</sup>	0.25 <sup>A,C</sup> 0.5 <sup>B</sup> 0.625 <sup>E</sup> 1.25 <sup>D</sup>
Repeatability	(mm)	± 0.05	± 0.1
Ambient temperature	(°C)	-20 – +70	-20 – +70
Linear movement / shaft revolution	(mm)	5 <sup>A</sup> 10 <sup>B,C</sup> 25 <sup>D,E</sup>	5 <sup>A</sup> 10 <sup>B,C</sup> 25 <sup>D,E</sup>
Max. input speed	(rpm)	1500 <sup>C,E</sup> 3000 <sup>A,B,D</sup>	1500 <sup>C,E</sup> 3000 <sup>A,B,D</sup>
Weight when single saddle	(kg)	9.0 + (L <sup>F</sup> x 17.2)	8.5 + (L <sup>F</sup> x 14.2)
Weight when double saddles	(kg)	13.0 + (L <sup>F</sup> x 17.2)	12.0 + (L <sup>F</sup> x 14.2)
Weight per pair screw supports	(kg)	1	1

<sup>A</sup> At pitch 5 mm <sup>B</sup> At pitch 10 mm <sup>C</sup> At pitch 10 mm (composite nut) <sup>D</sup> At pitch 25 mm <sup>E</sup> At pitch 25 mm (composite nut) <sup>F</sup> L in meters, see figure 1

Table 8

Movopart MF(G)10B		MF10B	MG10B
Max. speed	(m/s)	5	5
Max. belt force	(N)	1250	1250
Repeatability	(mm)	± 0.1	± 0.2
Ambient temperature	(°C)	-20 – +70	-20 – +70
Linear movement / shaft revolution	(mm)	176	176
Max. input speed	(rpm)	1700	1700
Weight when single saddle	(kg)	8.6 + (L <sup>A</sup> x 14.3)	7.8 + (L <sup>A</sup> x 11.6)
Weight when double saddles	(kg)	12.9 + (L <sup>A</sup> x 14.3)	11.3 + (L <sup>A</sup> x 11.6)

<sup>A</sup> L in meters, see figure 1

Table 9

Movopart MF(G)10N		MF10N	MG10N
Max. speed	(m/s)	5	5
Ambient temperature	(°C)	-20 – +70	-20 – +70
Weight when single saddle	(kg)	5.8 + (L <sup>A</sup> x 13.7)	5 + (L <sup>A</sup> x 11)
Weight when double saddles	(kg)	10.1 + (L <sup>A</sup> x 13.7)	8.5 + (L <sup>A</sup> x 11)

<sup>A</sup> L in meters, see figure 1

Table 10

Movopart MF(G)07K		MF07K	MG07K
Max. speed	(m/s)	0.25 <sup>A</sup> 0.63 <sup>B</sup> 1 <sup>C</sup>	0.25 <sup>A</sup> 0.63 <sup>B</sup> 1 <sup>C</sup>
Repeatability	(mm)	± 0.05	± 0.1
Ambient temperature	(°C)	-20 – +70	-20 – +70
Linear movement / shaft revolution	(mm)	5 <sup>A</sup> 12.7 <sup>B</sup> 20 <sup>C</sup>	5 <sup>A</sup> 12.7 <sup>B</sup> 20 <sup>C</sup>
Max. input speed	(rpm)	3000	3000
Weight when single saddle	(kg)	4.5 + (L <sup>D</sup> x 10.5)	4.2 + (L <sup>D</sup> x 8.2)
Weight when double saddles	(kg)	6.5 + (L <sup>D</sup> x 10.5)	5.9 + (L <sup>D</sup> x 8.2)
Weight per pair screw supports	(kg)	0.8	0.8

<sup>A</sup> At pitch 5 mm <sup>B</sup> At pitch 12.7 mm <sup>C</sup> At pitch 20 mm <sup>D</sup> L in meters, see figure 1

Table 11

Movopart MF(G)07B		MF07B	MG07B
Max. speed	(m/s)	5	5
Max. belt force	(N)	900	900
Repeatability	(mm)	± 0.1	± 0.2
Ambient temperature	(°C)	-20 – +70	-20 – +70
Linear movement / shaft revolution	(mm)	130	130
Max. input speed	(rpm)	2300	2300
Weight when single saddle	(kg)	4.7 + (L <sup>A</sup> x 8.8)	4.2 + (L <sup>A</sup> x 6.7)
Weight when double saddles	(kg)	6.7 + (L <sup>A</sup> x 8.8)	5.7 + (L <sup>A</sup> x 6.7)

<sup>A</sup> L in meter, see figure 1

Table 12

<b>Movopart MF(G)07N</b>		<b>MF07N</b>	<b>MG07N</b>
Max. speed	(m/s)	5	5
Ambient temperature	(°C)	-20 – +70	-20 – +70
Weight when single saddle	(kg)	3 + (L <sup>A</sup> x 8.3)	2.5 + (L <sup>A</sup> x 6.2)
Weight when double saddles	(kg)	5 + (L <sup>A</sup> x 8.3)	4 + (L <sup>A</sup> x 6.2)

<sup>A</sup> L in meter, see figure 1

Table 13

<b>Movopart MF(G)06C(K)</b>		<b>MF06C, MF06K</b>	<b>MG06C, MG06K</b>
Max. speed	(m/s)	0.25 <sup>A</sup> 0.254 <sup>B</sup> 0.5 <sup>C</sup> 1 <sup>D</sup> 0.8 <sup>E</sup>	0.25 <sup>A</sup> 0.254 <sup>B</sup> 0.5 <sup>C</sup> 1 <sup>D</sup> 0.8 <sup>E</sup>
Repeatability	(mm)	± 0.05	± 0.1
Ambient temperature	(°C)	-20 – +70	-20 – +70
Linear movement / shaft revolution	(mm)	5 <sup>A</sup> 5.08 <sup>B</sup> 10 <sup>C</sup> 20 <sup>D</sup> 32 <sup>E</sup>	5 <sup>A</sup> 5.08 <sup>B</sup> 10 <sup>C</sup> 20 <sup>D</sup> 32 <sup>E</sup>
Max. input speed	(rpm)	1500 <sup>E</sup> 3000 <sup>A,B,C,D</sup>	1500 <sup>E</sup> 3000 <sup>A,B,C,D</sup>
Weight when single saddle	(kg)	2.2 + (L <sup>F</sup> x 5.6)	2.2 + (L <sup>F</sup> x 4.4)
Weight when double saddles	(kg)	3.1 + (L <sup>F</sup> x 5.6)	3.1 + (L <sup>F</sup> x 4.4)
Weight per pair screw supports	(kg)	0.6	0.6

<sup>A</sup> At pitch 5 mm <sup>B</sup> At pitch 5.08 mm <sup>C</sup> At pitch 10 mm <sup>D</sup> At pitch 20 mm <sup>E</sup> At pitch 32 mm (composite nut) <sup>F</sup> L in meter, see figure 1

Table 14

<b>Movopart MF(G)06B</b>		<b>MF06B</b>	<b>MG06B</b>
Max. speed	(m/s)	5	5
Max. belt force	(N)	400	400
Repeatability	(mm)	± 0.1	± 0.2
Ambient temperature	(°C)	-20 – +70	-20 – +70
Linear movement / shaft revolution	(mm)	105	105
Max. input speed	(rpm)	2857	2857
Weight when single saddle	(kg)	3.1 + (L <sup>A</sup> x 5.3)	3.0 + (L <sup>A</sup> x 4.1)
Weight when double saddles	(kg)	4.3 + (L <sup>A</sup> x 5.3)	4.1 + (L <sup>A</sup> x 4.1)

<sup>A</sup> L in meter, see figure 1

Table 15

<b>Movopart MF(G)06N</b>		<b>MF06N</b>	<b>MG06N</b>
Max. speed	(m/s)	5	5
Ambient temperature	(°C)	-20 – +70	-20 – +70
Weight when single saddle	(kg)	1.8 + (L <sup>A</sup> x 5.1)	1.7 + (L <sup>A</sup> x 3.9)
Weight when double saddles	(kg)	3.0 + (L <sup>A</sup> x 5.1)	2.8 + (L <sup>A</sup> x 3.9)

<sup>A</sup> L in meter, see figure 1

Table 16

www.thomsonlinear.com

**EUROPE****United Kingdom**

Thomson  
Office 9, The Barns  
Caddsdow Business Park  
Bideford  
Devon, EX39 3BT  
Phone: +44 (0) 1271 334 500  
E-mail: sales.uk@thomsonlinear.com

**Germany**

Thomson  
Nürtinger Straße 70  
72649 Wolfschlügen  
Phone: +49 (0) 7022 504 0  
Fax: +49 (0) 7022 504 405  
E-mail: sales.germany@thomsonlinear.com

**France**

Thomson  
Phone: +33 (0) 243 50 03 30  
Fax: +33 (0) 243 50 03 39  
E-mail: sales.france@thomsonlinear.com

**Italy**

Thomson  
Largo Brughetti  
20030 Bovisio Masciago  
Phone: +39 0362 594260  
Fax: +39 0362 594263  
E-mail: info@thomsonlinear.it

**Spain**

Thomson  
E-mail: sales.esm@thomsonlinear.com

**Sweden**

Thomson  
Estridsväg 10  
29109 Kristianstad  
Phone: +46 (0) 44 24 87 00  
Fax: +46 (0) 44 24 40 85  
E-mail: sales.scandinavia@thomsonlinear.com

**SOUTH AMERICA****Brazil**

Thomson  
Av. Tamboré, 1077  
Barueri, SP – 06460-000  
Phone: +55 (11) 3816-0191  
Fax: +55 (11) 3611-1982  
E-mail: sales.brasil@thomsonlinear.com

**USA, CANADA and MEXICO**

Thomson  
203A West Rock Road  
Radford, VA 24141, USA  
Phone: 1-540-633-3549  
Fax: 1-540-633-0294  
E-mail: thomson@thomsonlinear.com  
Literature: literature.thomsonlinear.com

**ASIA****Asia Pacific**

Thomson  
E-mail: sales.apac@thomsonlinear.com

**China**

Thomson  
Rm 2205, Scitech Tower  
22 Jianguomen Wai Street  
Beijing 100004  
Phone: +86 400 6661 802  
Fax: +86 10 6515 0263  
E-mail: sales.china@thomsonlinear.com

**India**

Thomson  
c/o Fluke Technologies Pvt. Ltd.  
#424, Deodhar Center,  
Marol Maroshi Road,  
Andheri – E, Mumbai – 400059 India  
Phone: +91 22 29207641  
E-mail: sales.india@thomsonlinear.com

**Japan**

Thomson  
Minami-Kaneden 2-12-23, Suita  
Osaka 564-0044 Japan  
Phone: +81-6-6386-8001  
Fax: +81-6-6386-5022  
E-mail: csjapan@scgap.com

**Korea**

Thomson  
F7 Ilsong Bldg, 157-37  
Samsung-dong, Kangnam-gu,  
Seoul, Korea (135-090)  
Phone: +82 2 8917 5049  
Fax: +82 2 528 1456  
E-mail: sales.korea@thomsonlinear.com